



IHI SUPER SQUARE PARKING SYSTEM



Space OPTIMIZATION

Minimum space required for cars to manoeuvre around, Maximum parking space in constraint area.

UNIVERSAL Design-Compatible

IHI Flat Pallet as a standard feature means the Parking System is accessible with wheel chairs.

Lessened Waiting Time

With use of algorithmic route calculation, the system can instantly configure shortest route to the lift.

STANDARD SPECIFICATION / 仕様

PRODUCT NAME 品名	IHI SUPER SQUARE PARKING SYSTEM	
MODEL NUMBER 型式	BG-SSP	
REGISTRATION NUMBER 認定番号		
PARKING CAPACITY 収容台数	APPROXIMATELY 30 ~ 80 PARKING PER SYSTEM TYPE G1	
MAXIMUM VEHICLE SIZE 最大収容車寸	SEDAN (普通車)	SUV (ハイムワゴン)
	LENGTH 全長 5,300 mm	5,300 mm
MAXIMUM ACCEPTED VEHICLE SIZE 最大収容車寸	WIDTH 全幅 1,950 mm	1,950 mm
	HEIGHT 全高 1,550 mm	2,050 mm
MAXIMUM LOAD 最大積載量	90 mm	90 mm
	2,300 kg	2,500 kg
REMARKS 注意		
	NO VEHICLE SHALL BE PARKED WITHOUT FOLDING THE SIDE MIRRORS. 車両のサイドミラーを折り倒さずには駐車できません。	
	VEHICLE EXCEEDING FRONT OVERHANG OF 995MM, AND/OR VEHICLE EXCEEDING WHEEL BASE + REAR OVERHANG OF 4090MM CANNOT BE ACCEPTED. 全長が995mmを超え、かつホイールベース+リアオーバーハングが4090mmを超えない車両のみが受け入れられます。	
MODEL TYPE 型式	2-LEAF UP-SLIDING PANEL DOOR (2枚上開きパネルドア)	
MODEL DIMENSIONS 車寸	WIDTH 2,680 mm HEIGHT 2,200 mm	
OPERATION METHOD 操作方法	RFID CARD WITH NUMERICAL KEYPAD (ICカード式テンキー付) 22kWx1 27m/min 2.2kWx1 5.3rpm	
ACTUATOR & SPEED 駆動装置・速度	TURBOWHEEL ターボホイール 0.75kWx2 70m/min 35m/min 0.4kWx1 8.75rpm	
SLIDING FLOOR 滑り床	ELECTROMAGNETIC CLUTCH BRAKE (無励磁作動電磁ブレーキ) MIN 3φ 3W AC200V50Hz 60.0 KVA PER SYSTEM (1基当り) *STEP-DOWN TRANSFORMER REQUIRED TO COMPLY WITH THAI POWER SUPPLY MIN 1φ 2W AC100V50Hz 5.0 KVA PER SYSTEM (1基当り) *STEP-DOWN TRANSFORMER REQUIRED TO COMPLY WITH THAI POWER SUPPLY	
POWER (3-PHASE) 電力 (3相)	ELECTRICAL CONTROL SIZE 電気制御装置の寸法	
POWER (1-PHASE) 電力 (1相)	GROUND TYPE 接地方式	
ELECTRICAL GROUND 電気配線	GROUND (3-PHASE) 接地 (3相) 22 m ² OR LARGER CLASS D	
	GROUND (1-PHASE) 接地 (1相) 22 m ² OR LARGER CLASS D	

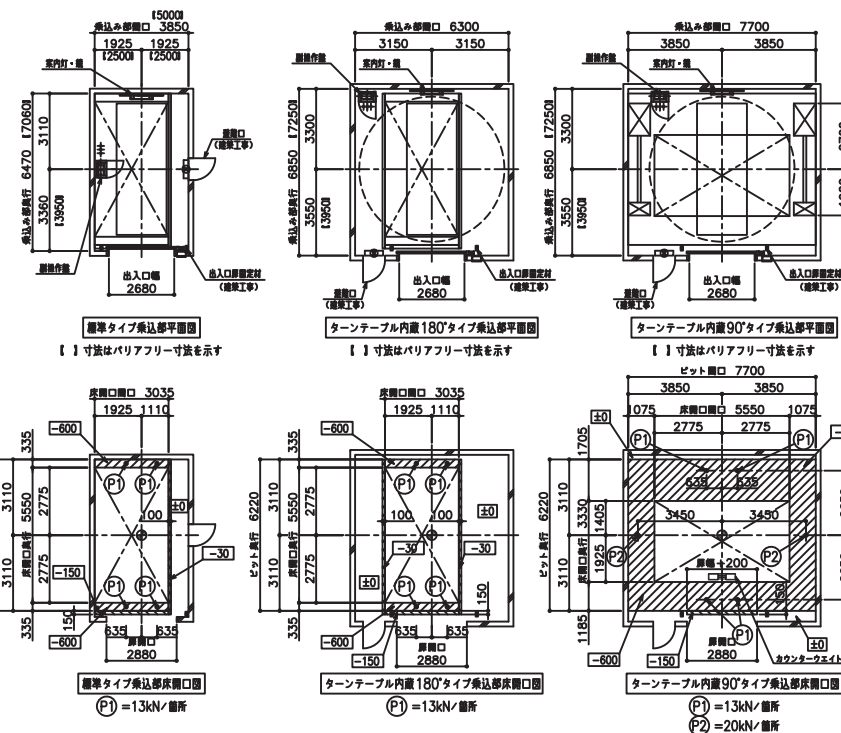
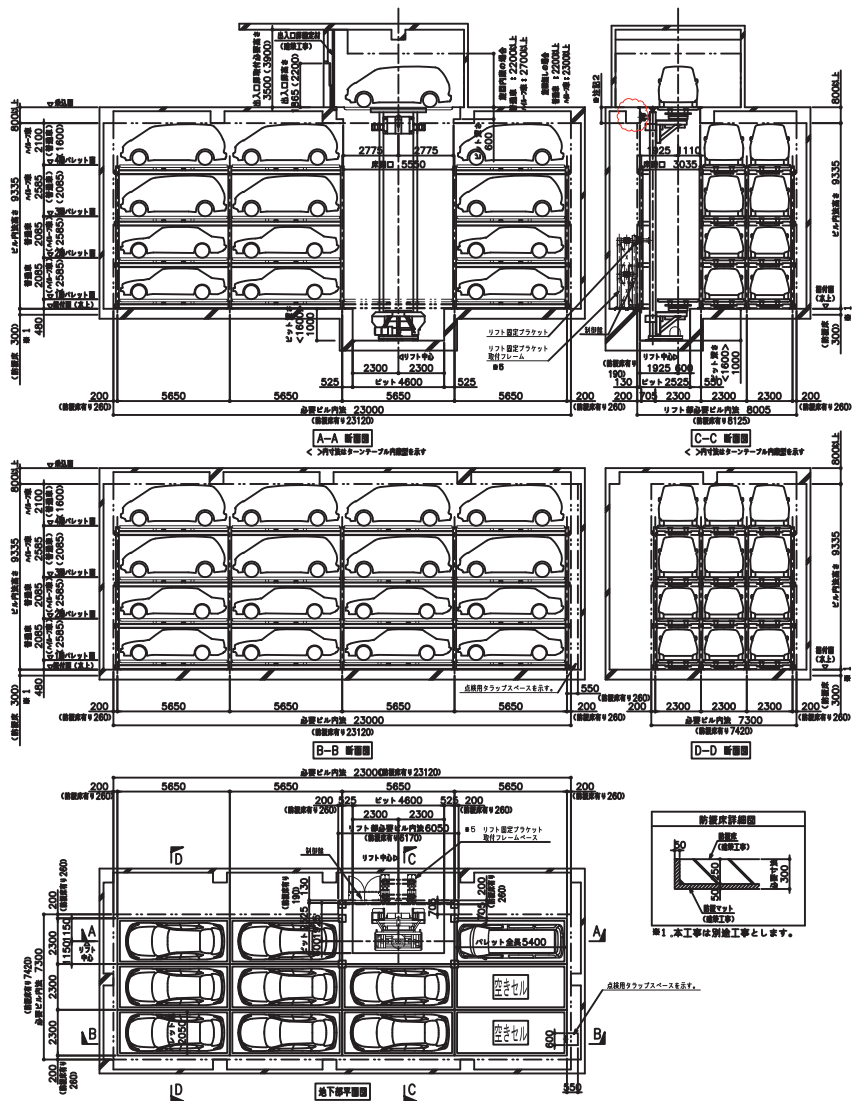

*DIMENSIONS STATED ABOVE ARE NOT TO SCALE;
FOR FURTHER DETAIL, PLEASE CONTACT IHI'S
SALES REPRESENTATIVES.

IHI Realize your dreams

IHI ASIA PACIFIC (THAILAND) CO., LTD.

11th Floor, Ramaland Building, 952 Rama IV Road, Suriyawongse, Bangrak, Bangkok 10500, THAILAND

Tel: +66 2 236-3490 / 9099 Fax: +66 2 236-7340 E-mail: thiapt-sales-thai@ihi-g.com WEB: <http://www.ihiapt.co.th/>